

INSTALLATION INSTRUCTIONS

CompactRIO™ Reconfigurable Embedded System

cRIO-9101/9102/9103/9104 Chassis

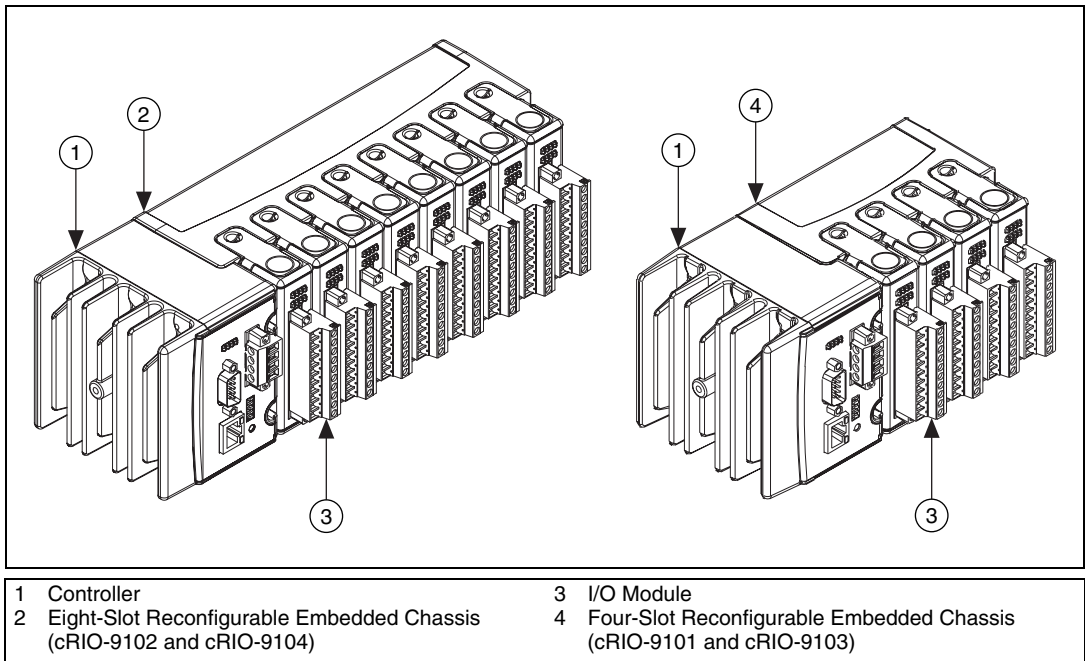

Figure 1. CompactRIO Four-Slot and Eight-Slot Reconfigurable Embedded Systems

These installation instructions describe how to install the National Instruments CompactRIO Reconfigurable Embedded System which consists of the CompactRIO controller, CompactRIO I/O modules, and the cRIO-9101, cRIO-9102, cRIO-9103, or cRIO-9104 reconfigurable embedded chassis (referred to inclusively as the cRIO-910x). For information about wiring the I/O modules, connecting the controller to the network, and configuring and programming the CompactRIO system, refer to the *CompactRIO Bookshelf* at **Start»Program Files»National Instruments»CompactRIO»Search the CompactRIO Bookshelf**.

Safety Guidelines

Operate the cRIO-910x only as described in these operating instructions.

Safety Guidelines for Hazardous Locations

The cRIO-910x is suitable for use in Class I, Division 2, Groups A, B, C, and D hazardous locations; Class 1, Zone 2, AEx nC IIC T4 and Ex nC IIC T4 hazardous locations; and nonhazardous locations only. Follow these guidelines if you are installing the cRIO-910x in a potentially explosive environment. Not following these guidelines may result in serious injury or death.



Caution Do *not* disconnect I/O-side wires and connectors unless power has been switched off or the area is known to be nonhazardous.



Caution Do *not* remove modules unless power has been switched off or the area is known to be nonhazardous.



Caution Substitution of components may impair suitability for Class I, Division 2.



Caution For Zone 2 applications, install the CompactRIO system in an enclosure rated to at least IP 54 as defined by IEC 60529 and EN 60529.

Special Conditions for Safe Use in Europe

This equipment has been evaluated as EEx nC IIC T4 equipment under DEMKO Certificate No. 03 ATEX 0324020X. Each module is marked  II 3G and is suitable for use in Zone 2 hazardous locations.

What You Need to Install CompactRIO Reconfigurable Embedded Hardware

- CompactRIO reconfigurable embedded chassis
- CompactRIO intelligent real-time embedded controller
- CompactRIO I/O modules
- DIN rail mount kit (for DIN rail mounting only)
- Two M4 or number 10 panhead screws (for panel mounting only)
- Number 2 Phillips screwdriver
- Power supply

Installing the Controller on the Chassis

Figure 2 shows the dimensions of the CompactRIO controller.

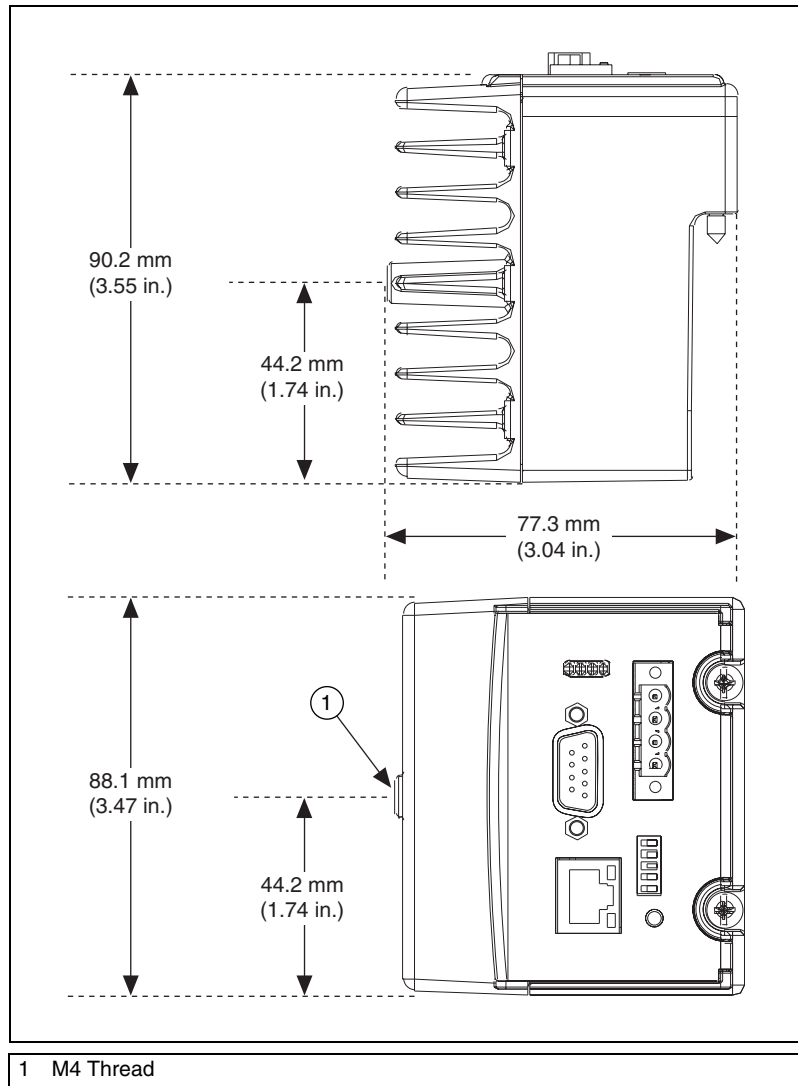

Figure 2. CompactRIO Controller, Front and Bottom View with Dimensions

Complete the following steps to install the controller on the chassis.

1. Make sure that no power is connected to the controller or the chassis.
2. Align the controller with the chassis as shown in Figure 3.

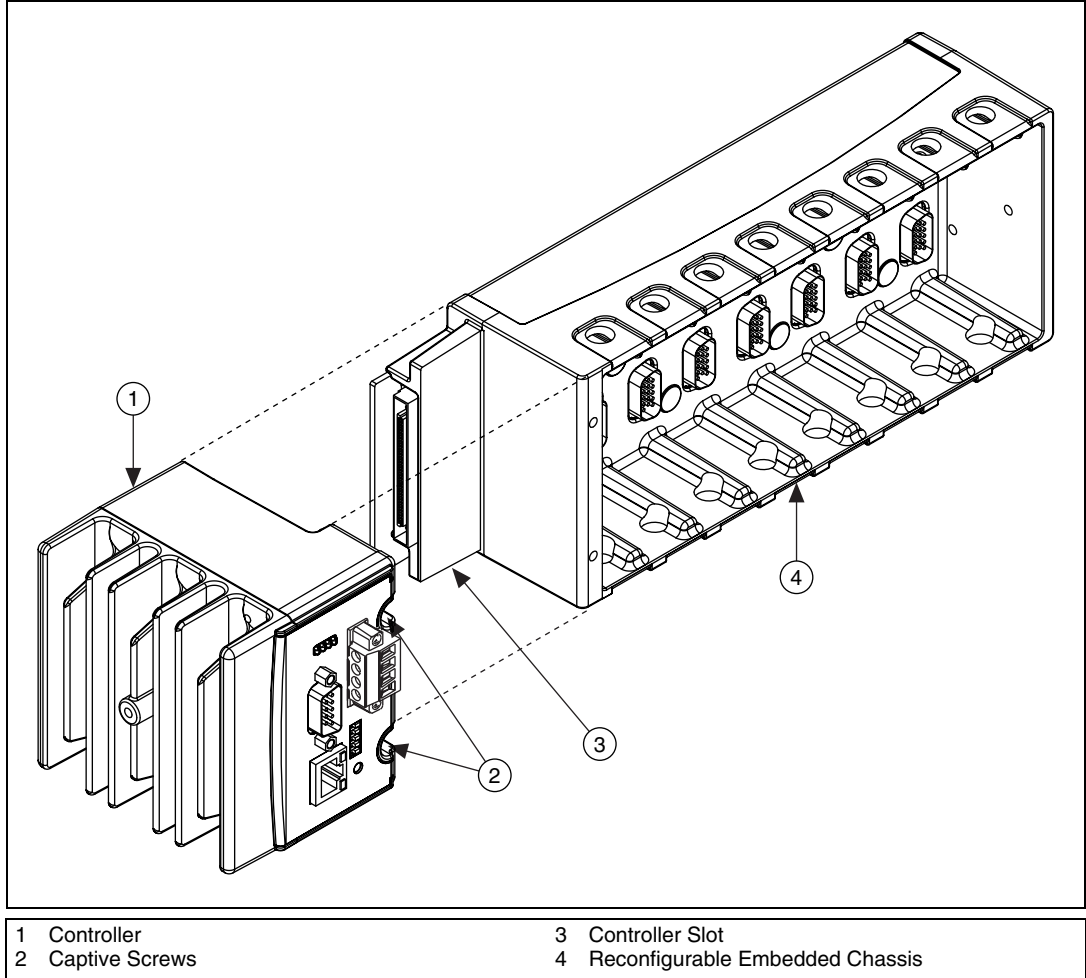

Figure 3. Installing the Controller on the Chassis (Eight-Slot Chassis Shown)

3. Slide the controller onto the controller slot on the chassis. Press firmly to ensure the chassis connector and the controller connector are mated.
4. Using a number 2 Phillips screwdriver, tighten the two captive screws on the front of the controller to $1.3 \text{ N} \cdot \text{m}$ ($11.5 \text{ lb} \cdot \text{in.}$) of torque.

Mounting the CompactRIO Reconfigurable Embedded Chassis

You can mount the chassis in any orientation on a 35 mm DIN rail or on a panel. Use the DIN rail mounting method if you already have a DIN rail configuration or if you need to be able to quickly remove the CompactRIO chassis. Use the panel mount method for high shock and vibration applications.



Caution Your installation must meet the following requirements for space and cabling clearance:

- Allow 25.4 mm (1 in.) on the top and the bottom of the chassis for air circulation.
- Allow 50.8 mm (2 in.) in front of modules for cabling clearance for common connectors, such as the 10-terminal, detachable screw terminal connector, as shown in Figure 4.

Go to ni.com/info and enter `rdcrioconn` to find the minimum cabling clearance for CompactRIO modules with other connector types.



Note Go to ni.com/hardref.nsf for more information about the dimensions of the CompactRIO system, including detailed dimensional drawings.

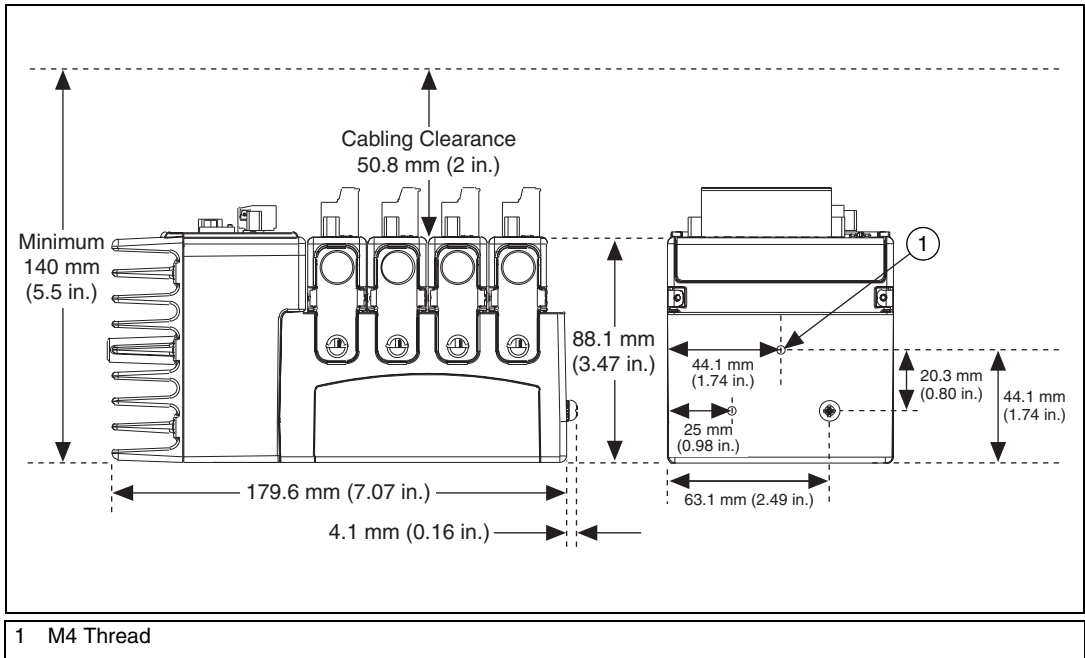

Figure 4. Four-Slot Reconfigurable Embedded Chassis with the Controller and I/O Modules Installed, Bottom and Side View with Dimensions

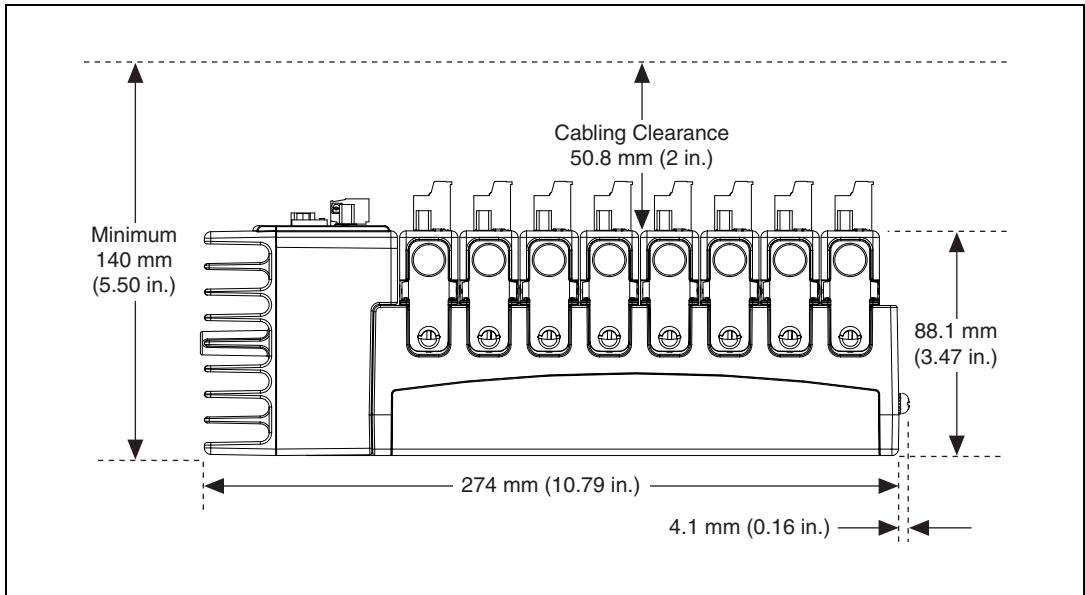

Figure 5. Eight-Slot Reconfigurable Embedded Chassis with the Controller and I/O Modules Installed, Bottom View with Dimensions

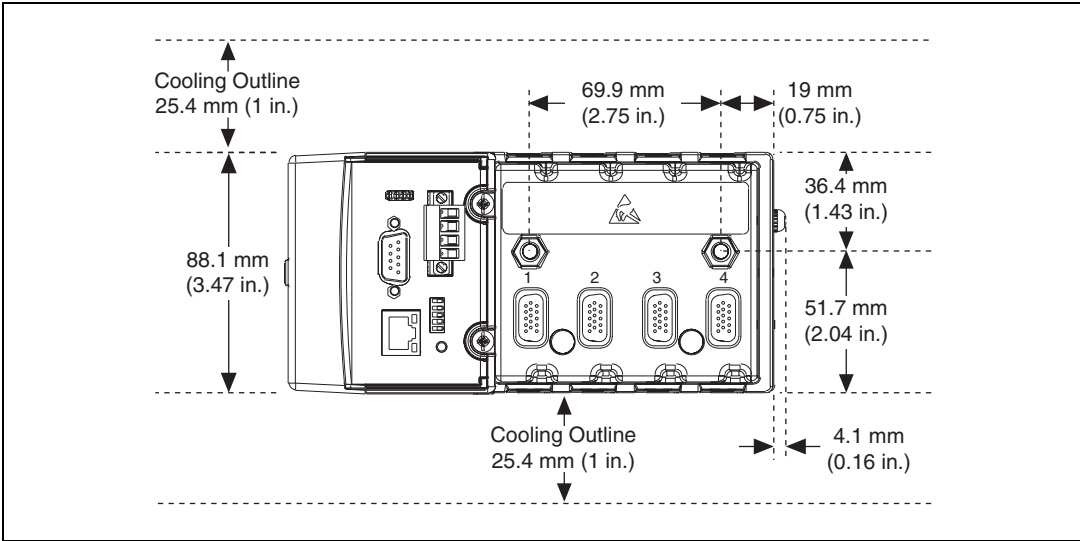

Figure 6. Four-Slot Reconfigurable Embedded Chassis with the Controller Installed, Front View with Dimensions

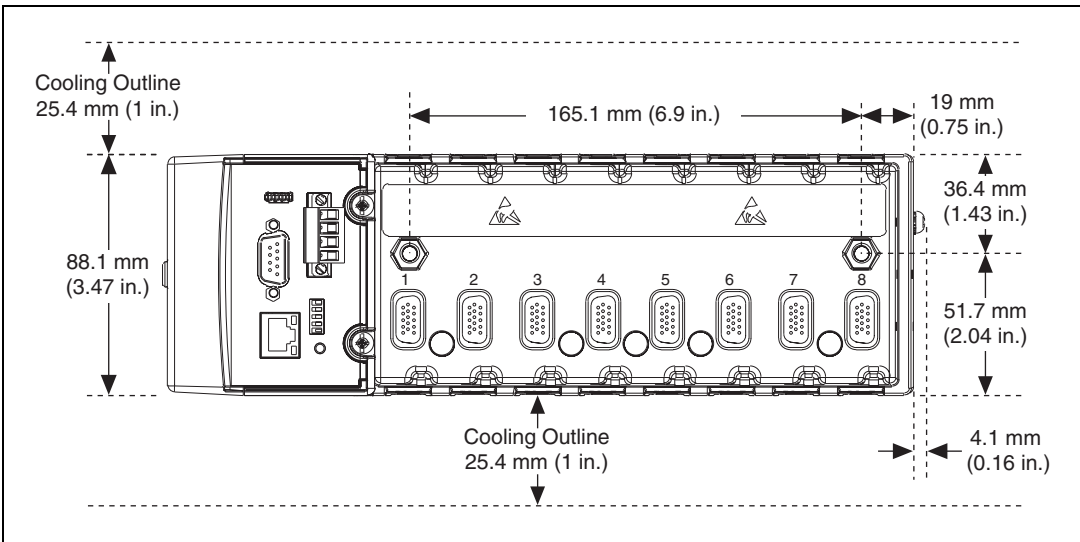

Figure 7. Eight-Slot Reconfigurable Embedded Chassis with the Controller Installed, Front View with Dimensions

The following sections give instructions for the mounting methods. Before using any of these mounting methods, record the serial number from the back of the chassis. You will be unable to read the serial number after you have mounted the chassis. You can mount the chassis on any material if the ambient temperature is 65 °C or less. If the ambient temperature is

66 to 70 °C, you must panel mount the chassis on a thermally conductive material. Measure the ambient temperature 50.8 mm (2 in.) from the end of the controller.



Caution Before you mount the chassis, make sure the I/O modules are not in the chassis.

Mounting the Chassis on a Panel

Complete the following steps to mount the chassis on a panel.

1. Align the chassis on the panel.
2. Bolt or screw the chassis to a panel using two M4 or number 10 panhead screws. National Instruments does not provide the screws with the chassis.

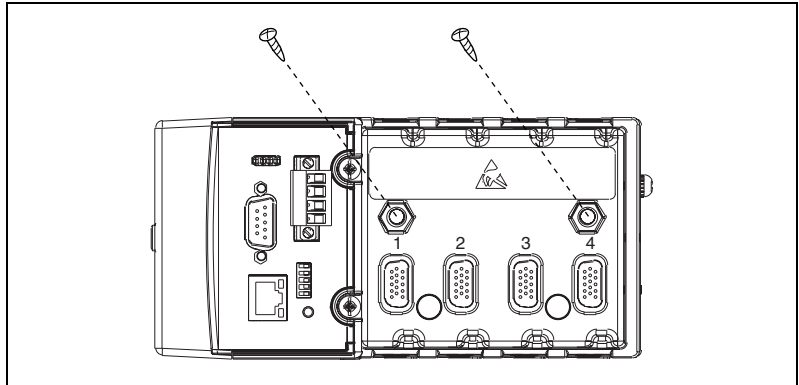

Figure 8. Mounting a Four-Slot Chassis on a Panel

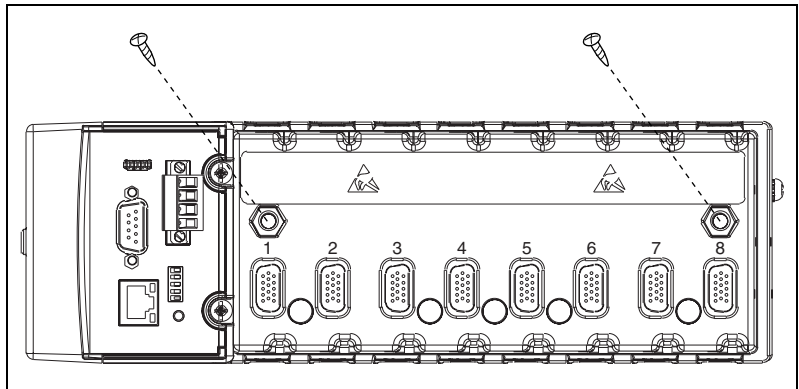

Figure 9. Mounting an Eight-Slot Chassis on a Panel



Caution Remove the I/O modules from the chassis before removing the chassis from the panel.

Mounting the Chassis on a DIN Rail

You can order the cRIO- 9912 DIN rail mount kit if you want to mount a four-slot CompactRIO chassis on a DIN rail or a cRIO-9915 DIN rail mount kit if you want to mount an eight-slot CompactRIO chassis on a DIN rail. You need one clip for mounting the chassis on a standard 35 mm DIN rail. Complete the following steps to mount the chassis on a DIN rail.

1. Fasten the DIN rail clip to the chassis using a number 2 Phillips screwdriver and two M4 × 16 screws. The screws are included in the DIN rail mount kit.

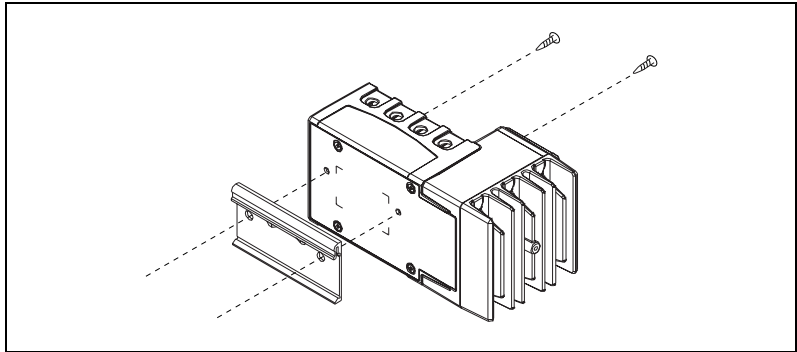

Figure 10. Fastening the DIN Rail Clip to a Four-Slot Chassis

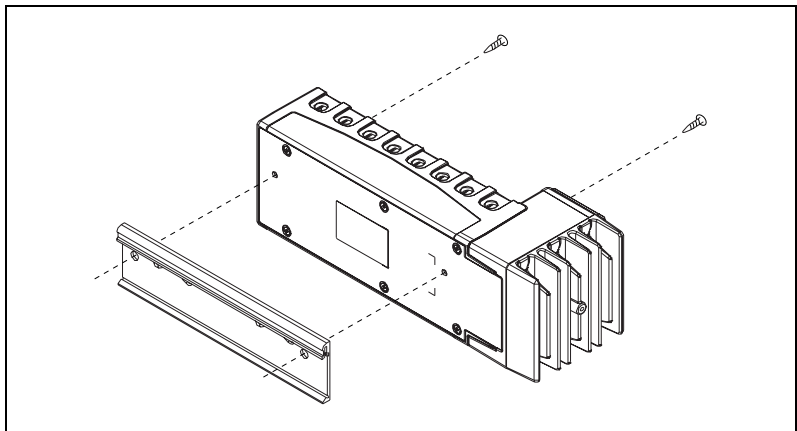

Figure 11. Fastening the DIN Rail Clip to an Eight-Slot Chassis

2. Insert one edge of the DIN rail into the deeper opening of the DIN rail clip, as shown in Figure 12.

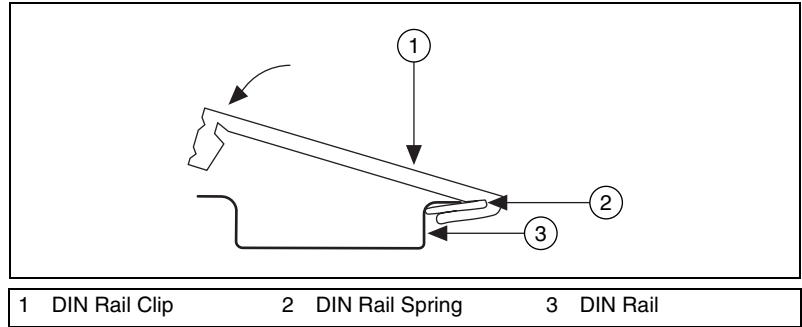

Figure 12. One Edge of the DIN Rail Inserted in a Clip

3. Press down firmly on the chassis to compress the spring until the clip locks in place on the DIN rail.



Caution Remove the I/O modules before removing the chassis from the DIN rail.

Installing CompactRIO I/O Modules in the Chassis

Figure 13 shows the mechanical dimensions of CompactRIO I/O modules.

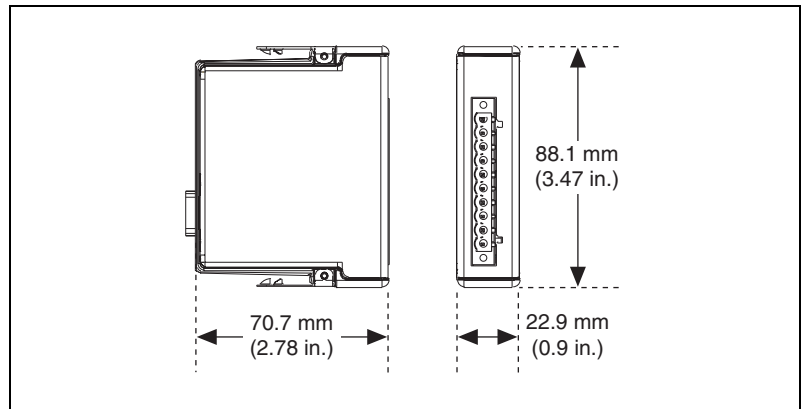

Figure 13. CompactRIO I/O Module, Front and Side View with Dimensions

Removing I/O Modules from the Chassis

Complete the following steps to remove a CompactRIO I/O module from the chassis

1. Make sure that no I/O-side power is connected to the I/O module. If the system is in a nonhazardous location, the chassis power can be on when you remove I/O modules.
2. Squeeze the latches on both sides of the module and pull the module out of the chassis.

Connecting the Controller to Power

Refer to the controller operating instructions to help you connect power to the controller. You can find the operating instructions at ni.com/manuals or in the *CompactRIO Bookshelf* at **Start»Program Files»National Instruments»CompactRIO»Search the CompactRIO Bookshelf**.

Calculating the Maximum Power Consumption/Dissipation of Your CompactRIO System

To calculate the power requirements of your CompactRIO system, add the power consumption/dissipation for the chassis, the controller, and the I/O modules you are using. Please keep in mind that the total power consumption is a maximum number and that the CompactRIO system may require less power in your application.

Connecting the Controller to the Network

Refer to the controller operating instructions to help you connect the controller to the network. You can find the operating instructions at ni.com/manuals or in the *CompactRIO Bookshelf* at **Start»Program Files»National Instruments»CompactRIO»Search the CompactRIO Bookshelf**.

Connecting I/O Modules to Field Devices

Refer to the operating instructions for each I/O module to help you connect field devices. You can find the operating instructions at ni.com/manuals or in the *CompactRIO Bookshelf* at **Start»Program Files»National Instruments»CompactRIO»Search the CompactRIO Bookshelf**.

Connecting the Chassis to Earth Ground

You must connect the panhead screw at the end of the chassis to ground. You must connect shielded cables to the panhead screw on the end of the chassis.

Where to Go from Here

You have completed installing the CompactRIO hardware. Now you need to configure the CompactRIO controller and chassis in National Instruments Measurement & Automation Explorer (MAX). For more information about configuring the controller and chassis in MAX, refer to the *Measurement & Automation Explorer Help*.

Specifications

The following specifications are typical for the range -40 to 70 °C unless otherwise noted. These specifications are for the cRIO-910x reconfigurable embedded chassis only. For the controller and I/O module specifications, refer to the operating instructions for the controller and I/O modules you are using.

Reconfigurable FPGA

cRIO-9101 and cRIO-9102	
Number of logic slices.....	5,120
Equivalent number of logic cells	11,520
Available embedded RAM	81,920 bytes
cRIO-9103 and cRIO-9104	
Number of logic slices.....	14,336
Equivalent number of logic cells	32,256
Available embedded RAM	196,608 bytes

Timebases.....	40, 80, 120, 160, or 200 MHz
Accuracy	±100 ppm (max)
Frequency dependent jitter	
40 MHz	250 ps
80 MHz	980 ps
120 MHz	970 ps
160 MHz	960 ps
200 MHz	950 ps

Power Requirements

These power requirements are for a full-loaded chassis and exclude the power requirements of the controller and the I/O modules in the chassis. For more information about the controller and the I/O module power requirements, refer to the operating instructions for the controller and for each I/O module.

Chassis power consumption/dissipation

cRIO-9101 and cRIO-9102

+5 VDC.....	500 mW (max)
+3.3 VDC.....	1,800 mW (max)
Total chassis power consumption.....	2,300 mW (max)

cRIO-9103 and cRIO-9104

+5 VDC.....	500 mW (max)
+3.3 VDC.....	2,500 mW (max)
Total chassis power consumption.....	3,000 mW (max)



Note The power consumption specifications in this document are maximum values for an application compiled at 40 MHz. Your application power requirements may be different. Go to ni.com/info and enter `rdcriotemp` for more information about the cRIO-910x power consumption and to help you understand your application power requirements.

Physical Characteristics

If you need to clean the chassis, wipe it with a dry towel.

Chassis weight

cRIO-9101 and cRIO-9103.....	Approx. 490 g (17.3 oz)
cRIO-9102 and cRIO-9104.....	Approx. 790 g (28 oz)

Safety

Safety Standards

The cRIO-910x is designed to meet the requirements of the following standards of safety for electrical equipment for measurement, control, and laboratory use:

- EN 61010-1, IEC 61010-1
- UL 3111-1, UL 61010B-1
- CAN/CSA C22.2 No. 1010.1



Note For UL and other safety certifications, refer to the product label or visit ni.com/hardref.nsf, search by model number or product line, and click the appropriate link in the Certification column.

Hazardous Locations

U.S. (UL)	Class I, Division 2, Groups A, B, C, D, T4; Class I, Zone 2, AEx nC IIC T4
Canada (C-UL)	Class I, Division 2, Groups A, B, C, D, T4; Class I, Zone 2, AEx nC IIC T4
Europe (DEMKO)	EEx nC IIC T4

Environmental

CompactRIO systems are intended for indoor use only. For outdoor use, mount the CompactRIO system in a suitably rated enclosure.

Operating temperature
(IEC-60068-2-1 and IEC-60068-2-2)-40 to 70 °C



Note For some applications, the operating temperature for the cRIO-910x is derated. Go to ni.com/info and enter `rdcriotemp` for more information about the cRIO-910x operating temperature and mounting specifications.

Storage temperature
(IEC-60068-2-1 and IEC-60068-2-2)-40 to 85 °C

Ingress protectionIP 40

Operating humidity (IEC-60068-2-56)...10 to 90% RH, noncondensing

Storage humidity (IEC-60068-2-56)5 to 95% RH, noncondensing

Maximum altitude 2,000 m

Pollution Degree (IEC 60664) 2

Shock and Vibration

To meet these specifications, you must panel mount the CompactRIO system and affix ferrules to the ends of the terminal lines.

Operating vibration,
random (IEC 60068-2-64)..... 5 g_{rms}, 10 to 500 Hz

Operating shock (IEC 60068-2-27)..... 30 g, 11 ms half sine,
50 g, 3 ms half sine,
18 shocks at 6 orientations

Operating vibration,
sinusoidal (IEC 60068-2-6)..... 5 g, 10 to 500 Hz

Electromagnetic Compatibility

Emissions EN 55011 Class A at 10 m
FCC Part 15A above 1 GHz

Immunity Industrial levels per EN
61326-1:1997 + A2:2001,
Table A.1

EMC/EMI..... CE, C-Tick, and FCC Part 15
(Class A) Compliant



Note For EMC compliance, you *must* operate this device with shielded cabling. The device must be connected to earth ground. For more information about connecting the device to earth ground, refer to the [Connecting the Chassis to Earth Ground](#) section.

FCC Compliance

Go to ni.com/info and enter `rdcriofcc` for more information on using this product in compliance with FCC regulations.

CE Compliance

This product meets the essential requirements of applicable European directives, as amended for CE marking, as follows:

Low-Voltage Directive (safety).....73/23/EEC

Electromagnetic Compatibility
Directive (EMC)89/336/EEC



Note Refer to the Declaration of Conformity (DoC) for this product for any additional regulatory compliance information. To obtain the DoC for this product, visit ni.com/hardref.nsf, search by model number, and click the appropriate link in the Certification column.

National Instruments Contact Information

National Instruments corporate headquarters is located at 11500 North Mopac Expressway, Austin, Texas, 78759-3504. National Instruments also has offices located around the world to help address your support needs. For telephone support in the United States, create a service request at ni.com/support and follow the calling instructions or dial 512 795 8248. For telephone support outside the United States, contact your local branch office:

Australia 1800 300 800, Austria 43 0 662 45 79 90 0,
Belgium 32 0 2 757 00 20, Brazil 55 11 3262 3599,
Canada (Calgary) 403 274 9391, Canada (Ottawa) 613 233 5949,
Canada (Québec) 450 510 3055, Canada (Toronto) 905 785 0085,
Canada (Vancouver) 514 685 7530, China 86 21 6555 7838,
Czech Republic 420 224 235 774, Denmark 45 45 76 26 00,
Finland 385 0 9 725 725 11, France 33 0 1 48 14 24 24,
Germany 49 0 89 741 31 30, Greece 30 2 10 42 96 427,
India 91 80 51190000, Israel 972 0 3 6393737, Italy 39 02 413091,
Japan 81 3 5472 2970, Korea 82 02 3451 3400, Malaysia 603 9131 0918,
Mexico 001 800 010 0793, Netherlands 31 0 348 433 466,
New Zealand 0800 553 322, Norway 47 0 66 90 76 60,
Poland 48 22 3390150, Portugal 351 210 311 210,
Russia 7 095 783 68 51, Singapore 65 6226 5886,
Slovenia 386 3 425 4200, South Africa 27 0 11 805 8197,
Spain 34 91 640 0085, Sweden 46 0 8 587 895 00,
Switzerland 41 56 200 51 51, Taiwan 886 2 2528 7227,
Thailand 662 992 7519, United Kingdom 44 0 1635 523545

CompactRIO™, National Instruments™, NI™, and ni.com™ are trademarks of National Instruments Corporation. Product and company names mentioned herein are trademarks or trade names of their respective companies. For patents covering National Instruments products, refer to the appropriate location: **Help»Patents** in your software, the `patents.txt` file on your CD, or ni.com/patents.
© 2004 National Instruments Corp. All rights reserved.



371559A-01

Jun04